



MP COMPACT BALL VALVE

Data Sheet



introduction

< STANDARDS >



ASTM D1784
ASTM D2466
ASTM D2467
ASTM D2464
ASTM F1498



ANSI B1.20.1



NSF 14/61

IPEX MP Compact Ball Valves are ideally suited to all kinds of plumbing and industrial applications where a compact, inexpensive on/off valve is required. The simple one piece PVC body with integral end connections eliminates potential problems caused by improper adjustment of the ball seating. MP Compact Ball Valves are part of our complete systems of pipe, valves, and fittings, engineered and manufactured to our strict quality, performance, and dimensional standards.

Valve Availability

Body Material:	PVC
Size Range:	1/2" through 2"
Pressure:	150 psi
Seats:	Teflon® (PTFE)
Seals:	EPDM
End Connections:	Socket (IPS), Threaded (FNPT)

Sample Specification



1.0 Ball Valves - MP

1.1 Material

- The valve body and ball shall be made of PVC compound which shall meet or exceed the requirements of cell classification 12454 according to ASTM D1784.
- These compounds shall comply with NSF Standard 14/61 for potable water.

1.2 Seats

- The ball seats shall be made of Teflon® (PTFE) which shall comply with NSF Standard 14/61 for potable water.

1.3 Seals

- The o-ring seals shall be made of EPDM which shall comply with NSF Standard 14/61 for potable water.

- 1.4 All other wetted and non-wetted parts of the valves shall comply with NSF Standard 14/61 for potable water.

2.0 Connections

2.1 Socket style

- The IPS socket PVC end connections shall conform to the dimensional standards ASTM D2466 and ASTM D2467.

2.2 Threaded style

- The female NPT threaded PVC end connections shall conform to the dimensional standards ASTM D2464, ASTM F1498, and ANSI B1.20.1.

3.0 Design Features

- The valve shall be composed of a one piece PVC body.
- The end connections shall be an integral part of the body.
- All sizes shall allow for bi-directional flow.

3.1 Pressure Rating

- All sizes shall be rated at 150 psi at 73°F (non-shock).

3.2 Markings

- All valves shall be marked to indicate size, material designation, and manufacturers name or trade mark.

3.3 Color Coding

- All PVC Schedule 40 valves shall be color-coded white.
- All PVC Schedule 80 valves shall be color-coded dark gray.

- 4.0 All valves shall be Xirtec® 140 by IPEX or approved equal.

Valve Selection



Size (inches)	Body Material	O-ring Material	IPEX Part Number		Pressure Rating
			IPS Socket	FNPT Threaded	
1/2	Sch 40 PVC	EPDM	052277	052283	150 psi
	Sch 80 PVC		052000	052026	
3/4	Sch 40 PVC		052278	052284	
	Sch 80 PVC		052006	052029	
1	Sch 40 PVC		052279	052285	
	Sch 80 PVC		052007	052107	
1-1/4	Sch 40 PVC		052280	052286	
	Sch 80 PVC		052009	052108	
1-1/2	Sch 40 PVC		052281	052287	
	Sch 80 PVC		052019	052109	
2	Sch 40 PVC		052282	052288	
	Sch 80 PVC		052024	052144	

Body Material:

- Sch 40 white PVC
- Sch 80 grey PVC

Size (inches):

- 1/2 1-1/4
- 3/4 1-1/2
- 1 2

End Connections:

- Socket (IPS)
- Threaded (FNPT)

IPEX Part Number:

Technical Data

dimensions and weights

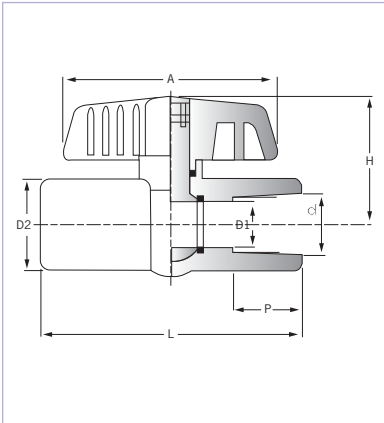

Size	Dimension (inches)								
	D1	d Socket	d Threaded	P	L	D2	H	A	W (lbs)
1/2	0.59	0.84	1/2 NPT	0.88	3.11	1.38	1.85	2.76	0.24
3/4	0.79	1.05	3/4 NPT	1.00	3.54	1.58	2.24	3.03	0.35
1	0.98	1.32	1 NPT	1.13	4.13	1.89	2.40	3.50	0.52
1-1/4	1.26	1.66	1-1/4 NPT	1.25	4.76	2.13	2.60	3.50	0.74
1-1/2	1.54	1.90	1-1/2 NPT	1.38	5.00	2.44	2.91	4.37	1.06
2	1.97	2.38	2 NPT	1.50	5.87	2.95	3.15	5.47	1.72

pressure – temperature ratings

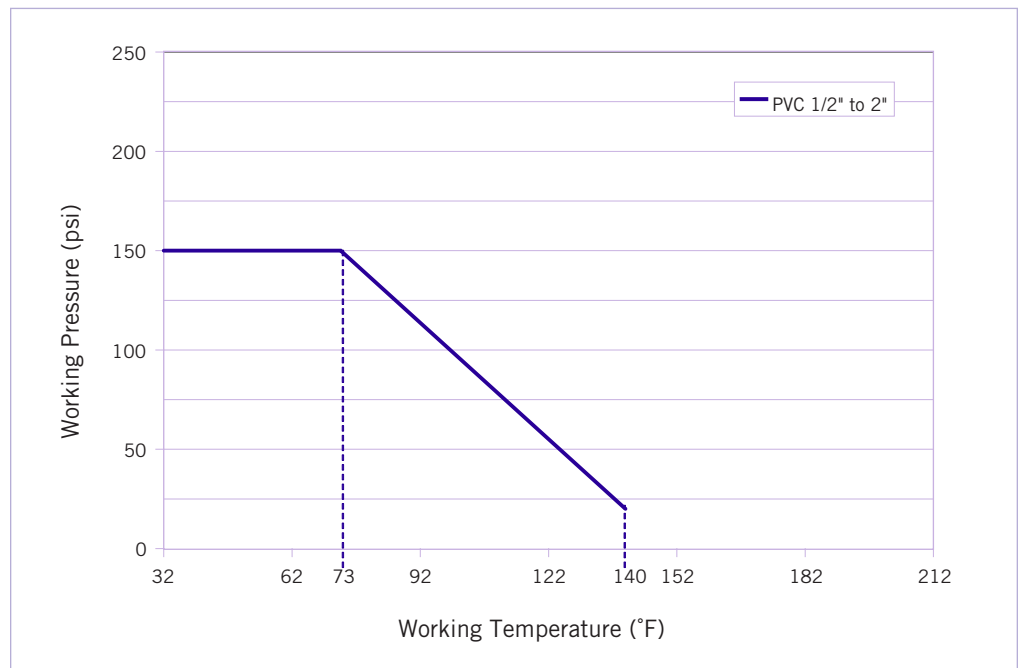

Technical Data (cont'd)

flow coefficients



The flow coefficient (CV) represents the flow rate in gallons per minute (GPM) at 68°F for which there is a 1 psi pressure drop across the valve in the fully open position. These values are determined from an industry standard testing procedure which uses water as the flowing media (specific gravity of 1.0). To determine specific flow rate and pressure loss scenarios, one can use the following formula:

$$f = sg \times \left(\frac{Q}{C_V} \right)^2$$

Where,

f is the pressure drop (friction loss) in psi,

sg is the specific gravity of the fluid,

Q is the flow rate in GPM,

C_V is the flow coefficient.

Size	CV
1/2	8.80
3/4	13.2
1	25.2
1-1/4	38.5
1-1/2	51.3
2	96.7

pressure loss chart

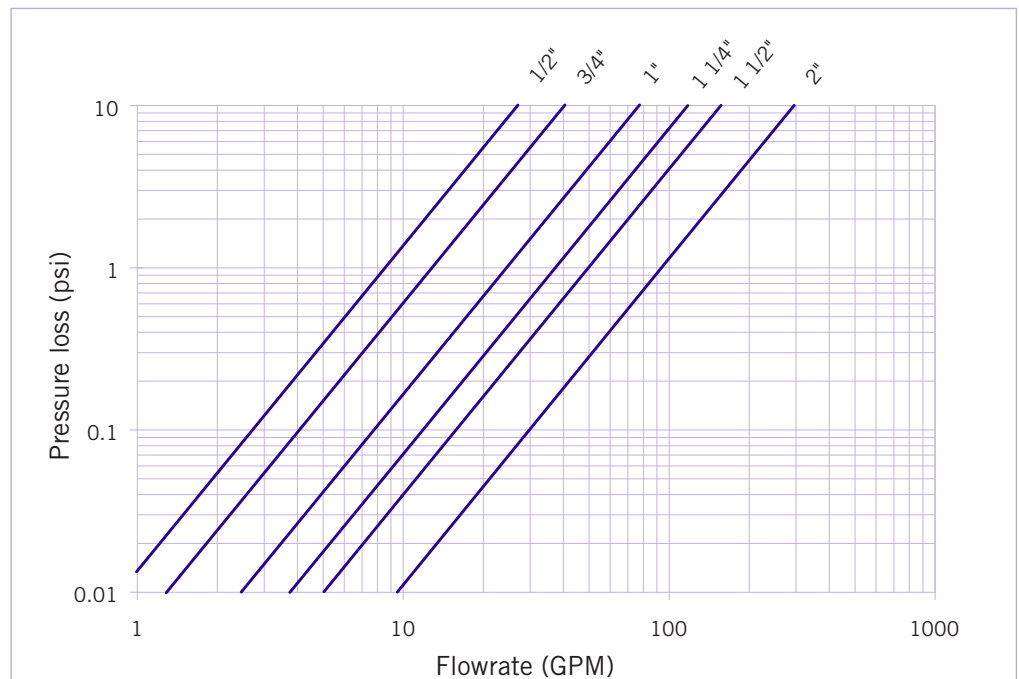

Components

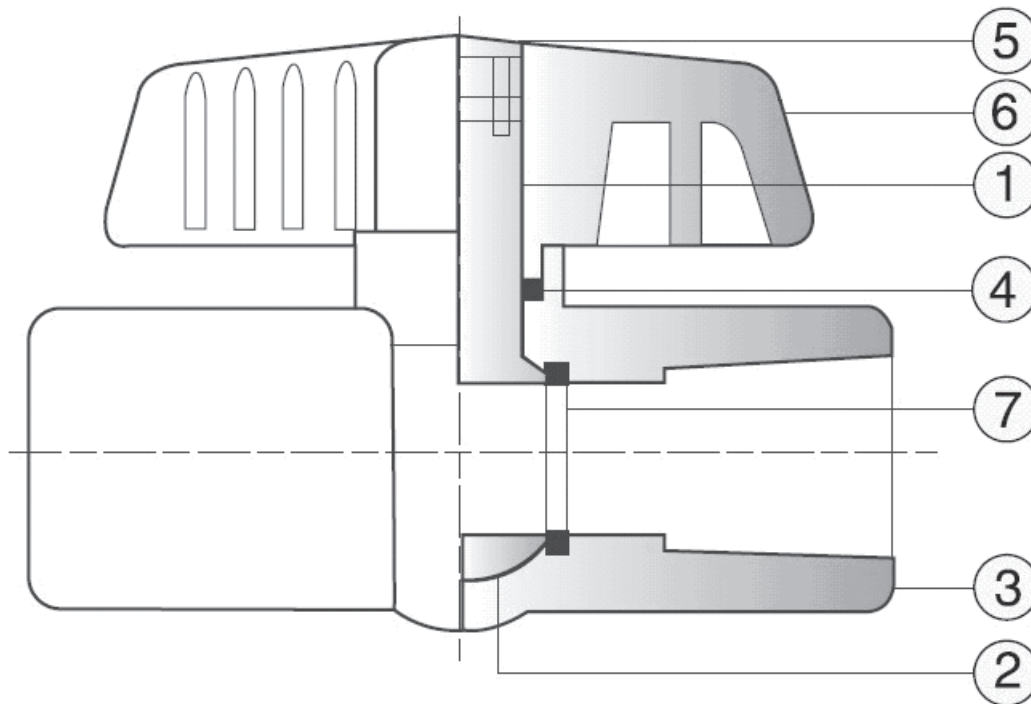

#	Component	Material	Qty
1	stem	PVC	1
2	ball	PVC	1
3	body	PVC (white) / PVC (grey)	1
4	stem o-ring	EPDM	1
5	cap	ABS	1
6	handle	ABS	1
7	seat	PTFE	2

Installation Procedures



1. Please refer to the appropriate connection style sub-section:
 - a. For socket style, solvent cement each pipe end into the body of the valve. For correct joining procedure, please refer to the section entitled, *“Joining Methods – Solvent Cementing”* in the IPEX Industrial Technical Manual Series, *“Volume I: Vinyl Process Piping Systems”*. **Be sure to allow sufficient cure time before pressurizing the system.**
 - b. For threaded style, thread each pipe end into the body of the valve. For correct joining procedure, please refer to the section entitled, *“Joining Methods – Threading”* in the IPEX Industrial Technical Manual Series, *“Volume I: Vinyl Process Piping Systems”*.

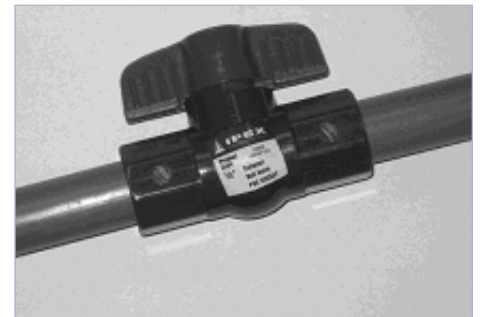

removal from the system

1. If removing the valve from an operating system, isolate the valve from the rest of the system. **Be sure to depressurize and drain the isolated branch and valve before continuing.**
2. Please refer to the appropriate connection style sub-section:
 - a. For socket style, cut the pipe as close to the ends of the valve body as possible. The valve can now be replaced.
 - b. For threaded style, unthread the pipe ends from the valve body. The valve can now be reused and/or replaced.

Note: The MP Compact Ball Valve is a molded-in-place valve. It cannot be disassembled.

Testing and Operating



The purpose of system testing is to assess the quality of all joints and fittings to ensure that they will withstand the design working pressure, plus a safety margin, without loss of pressure or fluid. Typically, the system will be tested and assessed in sub-sections as this allows for improved isolation and remediation of potential problems. With this in mind, the testing of a specific installed valve is achieved while carrying out a test of the overall system.

An onsite pressure test procedure is outlined in the IPEX Industrial Technical Manual Series, *"Volume I: Vinyl Process Piping Systems"* under the section entitled, *"Testing"*. The use of this procedure should be sufficient to assess the quality of a valve installation. In any test or operating condition, it is important to never exceed the pressure rating of the lowest rated appurtenance in the system.

Important points:

- Never test thermoplastic piping systems with compressed air or other gases including air-over-water boosters.
- When testing, do not exceed the rated maximum operating pressure of the valve.
- Avoid the rapid closure of valves to eliminate the possibility of water hammer which may cause damage to the pipeline or the valve.

For safety reasons, please contact IPEX customer service and technical support when using volatile liquids such as hydrogen peroxide (H₂O₂) and sodium hypochlorite (NaClO). These liquids may vaporize causing a potentially dangerous pressure increase in the dead space between the ball and the valve body.

Please contact IPEX customer service and technical support with regard to any concern not addressed in this data sheet or the technical manual.

About IPEX

IPEX is a leading supplier of thermoplastic piping systems. We provide our customers with one of the world's largest and most comprehensive product lines. All IPEX products are backed by over 50 years of experience. With state-of-the-art manufacturing facilities and distribution centers across North America, the IPEX name is synonymous with quality and performance.

Our products and systems have been designed for a broad range of customers and markets. Contact us for information on:

- PVC, CPVC, PP, FR-PVDF, ABS, PEX and PE pipe and fittings (1/4" to 48")
- Industrial process piping systems
- Double containment systems
- Acid waste systems
- High purity systems
- Industrial, plumbing and electrical cements
- Municipal pressure and gravity piping systems
- Plumbing and mechanical pipe systems
- Electrical systems
- Telecommunications systems
- Irrigation systems
- PE Electrofusion systems for gas and water
- Radiant heating systems

WARRANTY: All IPEX products are guaranteed against defects resulting from faulty workmanship or materials. If any such product is found to be defective by reason of faulty workmanship or materials, upon written notice and return of the product, the defective product will be replaced by IPEX free of charge, including shipping charges for the replacement product. Claims for labour costs and other expenses required to replace such defective product or to repair any damage resulting from the use thereof will not be allowed by IPEX. Our liability is limited to the price paid for the defective product. IPEX will not be bound by any warranty, other than the above set forth, unless such warranty is in writing.

This literature is published in good faith and is believed to be reliable. However, it does not represent and/or warrant in any manner the information and suggestions contained in this brochure. Data presented is the result of laboratory tests and field experience.

A policy of ongoing product improvement is maintained. This may result in modification of features and/or specifications without notice.